

Printable Area
11.250" Wraparound
1.625" Height

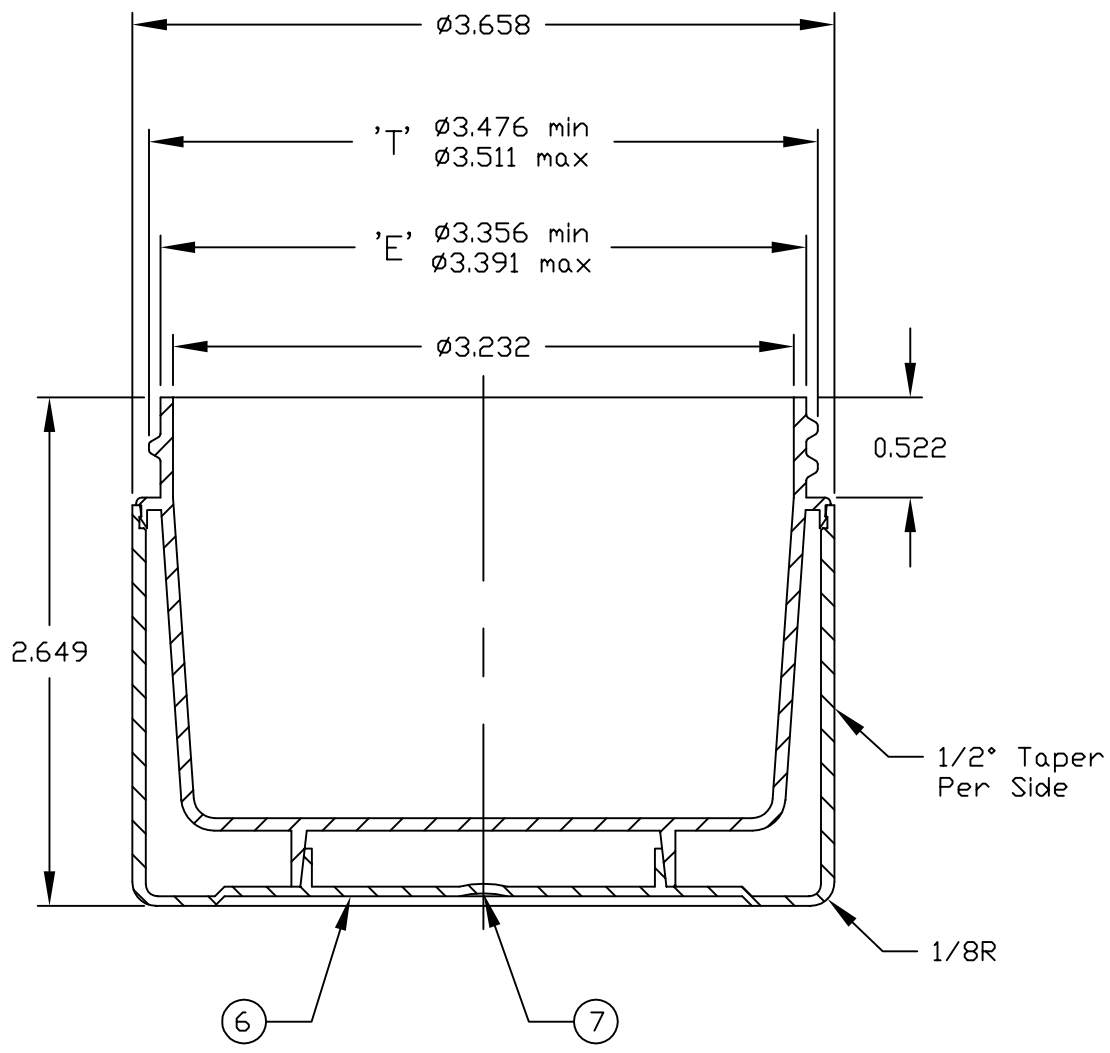

WARNING

This drawing is the property of Delta Plastics, Inc. Any unauthorized use, reproduction, or transmission of this document without the written consent of Delta Plastics, Inc. is strictly prohibited.

1. MATERIAL: INNER POLYPROPYLENE
OUTER POLYSTYRENE
2. 5 THREADS/INCH
3. OVERFLOW CAPACITY: APPROX. 282cc
4. ALL FILLETS & RADII TO BE: 0.010"
UNLESS OTHERWISE SPECIFIED
5. DRAFT TO BE: 1/2°
UNLESS OTHERWISE SPECIFIED
6. CAVITY NUMBER
7. GATE LOCATION: CENTER
8. WEIGHT: APPROX. 54.6 GRAMS
9. DELTA PART #: 3350



Delta Plastics, Inc.

CORPORATE OFFICE 106 Delta Place Hot Springs, AR 71913 (501) 760-3000 Fax: (501) 760-3005	TECH CENTER 15130 Northam Street La Mirada, CA 90638 (714) 670-6400 Fax: (714) 670-7500
---	---

TITLE:

8 oz. (89mm) STRAIGHT BASE
POLYSTYRENE OUTER
DOUBLE WALL JAR

DIM.		TOL.		REV.		DESC. OF CHANGE		DATE	
.00	.015	3	Taper(JBF)						3/13/03
.000	.010	2	print area(SPM)						9/18/02
DRAWN: JBF	DATE: 3/13/03	1	print area(JSO)						4/15/02
CHECKED:	DATE:	0	orig dwg(AHV)						1/16/01
SCALE: 1:1	DWG.# 3350	REV.	DESC. OF CHANGE						DATE